

INSTRUCTIONS

IMPORTANT SAFEGUARDS

When using electrical equipment, basic safety precautions should always be followed including the following:

- 1. READ AND FOLLOW ALL SAFETY INSTRUCTIONS**
2. Disconnect power before performing work on electrical equipment.
3. Do not use outdoors.
4. Do not let power cords touch hot surfaces and do not mount near gas or electric heaters.
5. Use caution when servicing batteries. Battery acid can cause burns to skin and eyes. If acid is spilled on skin or eyes, flush with fresh water and contact a physician immediately.
6. Equipment should be mounted in locations and/or at heights where unauthorized personnel will not readily subject it to tampering.
7. The use of replacement parts or accessory equipment not furnished by BeLuce Canada Inc., may cause equipment failure and will void the warranty.
8. Do not use this equipment for other than its intended purpose.
9. Servicing of this equipment should be performed by qualified service personnel.
- 10. SAVE THESE INSTRUCTIONS!**

OVERVIEW

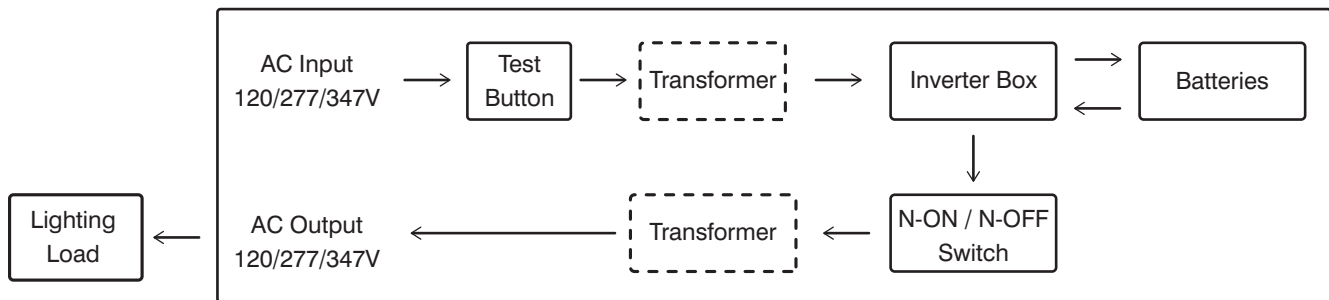

Input/Output:

120VAC / 120 or 277 or 347VAC, 60Hz
 277VAC / 120 or 277VAC, 60Hz
 347VAC / 120 or 347VAC, 60Hz

NO transformer if both input and output voltages are 120V
 Batteries MUST be connected for Inverter to turn ON

N-ON (Normally ON): unit will always provide AC output to lighting load when AC input is available, and during AC input failure

N-OFF (Normally OFF): unit will provide AC output to lighting load only when AC supply input fails

MAXIMUM SURGE VALUES: Inrush / Peak current factor of the lighting load should be considered while sizing lighting load for the inverter

- Nova UAC-P - 3000W for 0.5 seconds

This unit is **FLOOR MOUNT ONLY!**

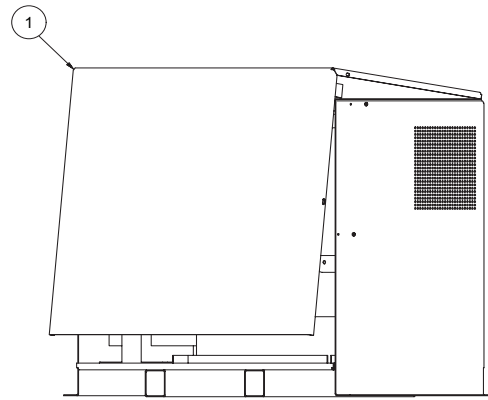
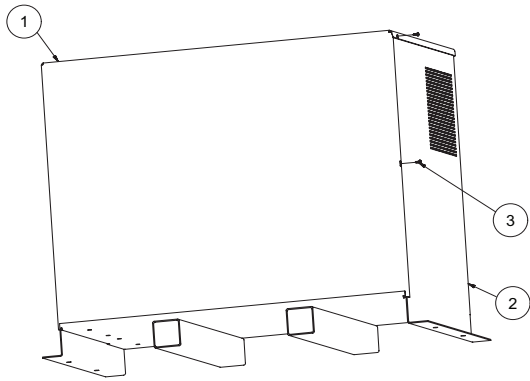

PARTS LIST

1. Cover
2. Cabinet
3. Screws
4. Test Switch
5. Diagnostic
6. Inverter
7. AT Board MT Shelf
8. Toggle Switch
9. Relay
10. Terminal Block
277 / 347V Option
11. Transformer
12. Battery
13. Inverter Display

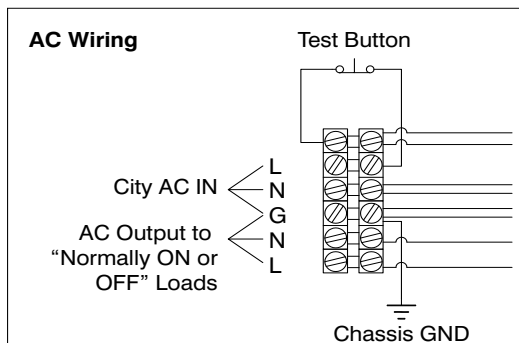
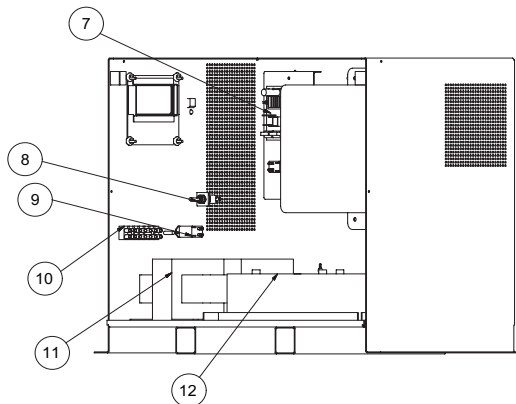
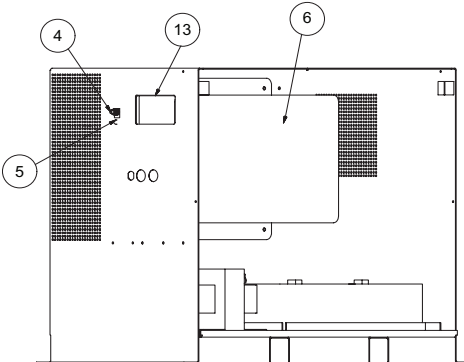

CAUTION

1. Verify on Lighting load wiring that the neutral conductor **IS NOT BONDED OR CONNECTED** to the ground wiring.
2. Inverter's AC output **MUST** be wired by its own line and neutral wires. **DO NOT connect the AC output neutral wire to any neutral wires in the building.**
3. If more than one inverter is installed, **DO NOT CONNECT** the neutrals of multiple AC outputs together.
4. **DO NOT CONNECT** the AC output line and neutral to the mains AC input line and neutral.
5. Observe battery polarity. RED is "+" POSITIVE and BLACK is "-" NEGATIVE.
6. The battery charging current has been factory set. **DO NOT** adjust it.
7. Disconnect ALL electrical sources including the inverter's AC and DC inputs before servicing.

MAINTENANCE

1. Allow 24 hours recharge time after installation or power failure before full load testing.
NOTE: DO NOT LEAVE BATTERIES CONNECTED TO INVERTER, WITHOUT AC INPUT SUPPLIED OR WITH UNIT SHUTDOWN, FOR A LONG DURATION.
2. Batteries may stop charging if unit detects a fault / error code; seek qualified support as soon as possible.
3. BeLuce Canada Inc. recommends that the equipment be tested and that written records be maintained according to the local building code.

INSTALLATION

Airflow is vital to the performance of this product.

Install with AT LEAST 12" (30cm / 300mm) clear space on both ends and do not block ventilation holes.

1. Extend un-switched 24-hour AC supply of rated voltage to the unit, installed in accordance with all applicable codes and standards. This circuit should NOT be energized/live at the time.
2. Unscrew the cover screws on the sides of the unit. Lift and remove the front cover (2).
3. Knockouts are stamped into the back and side of the cabinet. Knock out the appropriate hole(s) and bring wires through them into the cabinet.
4. Mount the unit securely into place. This unit is FLOOR MOUNT ONLY!
5. Make proper wiring connections between the AC supply and terminal blocks within the unit (6) (see AC Wiring diagram, page 2).
6. Make proper load connection to the terminal block (6) (see AC wiring diagram above).
7. Batteries are shipped separately. Install batteries into the cabinet and complete the appropriate connection:
Red wire to positive battery terminal (+) and Black wire to negative battery terminal (-).
8. Route wires and secure in place.
9. Select Load Operation Mode (N-ON / N-OFF) from the internal toggle switch (13).
10. Replace cover and secure with cover screws (2).
11. Turn on AC line voltage supply.

UNIT RESET

1. Disconnect AC input, disconnect batteries from inverter, disconnect load.
2. Wait 10 seconds; measure battery voltage during wait period to verify condition.
3. Reconnect batteries, and then reconnect AC input.
4. If unit turns ON with no error notifications, turn OFF unit with power button and disconnect AC before reconnecting lighting load.

TROUBLESHOOTING

Problems	Reasons	Solutions
No AC output voltage during emergency	Surge (or inrush) of lighting load exceeds inverter's maximum, causing unit shutdown	<ul style="list-style-type: none"> • Reduce number of connected lighting fixtures, or replace with lower-surge fixtures • Reset unit
No AC output voltage, with AC input present (N-ON mode only)	Lighting load exceeds inverter's maximum capacity, causing unit shutdown	<ul style="list-style-type: none"> • Reduce number of connected lighting fixtures • Reset unit
	Short-circuit, causing AC output circuit breaker to trip	<ul style="list-style-type: none"> • Locate and clear short-circuit • Reset circuit breaker located on inverter box inside the unit enclosure
Unit does not turn ON, with AC input present	Battery voltage is lower than acceptable threshold	<ul style="list-style-type: none"> • Disconnect battery and recharge by separate means; battery may need replacement
	Battery is not connected to inverter box	<ul style="list-style-type: none"> • Connect 12V battery terminals to inverter
Unit does not last up to required emergency duration	Battery is not fully charged	<ul style="list-style-type: none"> • Allow battery recharge for up to 24 hours
	Lighting load exceeds unit rating	<ul style="list-style-type: none"> • Reduce number of connected lighting fixtures to below unit power rating
	Batteries are defective, or aging	<ul style="list-style-type: none"> • Replace batteries