

SLT

LED STRIP WITH SENSOR

Type: _____

Project: _____

Delivered Lumens:
4,585 lm

Input Wattage:
35W

Efficacy:
132 lm/W

Colour Temperatures:
4000K

CRI:
80+

Projected Lumen Maintenance:
L₇₀ @ 155,000 hrs.

The **SLT** features an integrated tri-level microwave motion sensor that regulates light levels according to the occupancy of a space.

Integrated tri-level microwave (high frequency) motion sensor.

Sleek design ideal for installation in tight spaces. Suitable for damp locations.



Contoured frosted PMMA diffuser.

Enclosed lens prevents penetration of dust, insects, and other debris into the LED compartment.

The **SLT** LED strip lights have been designed to prevent energy loss and to increase energy savings by allowing the end-user to sensibly manage the degree of luminosity in applications or spaces that require continuous lighting, such as hallways and common areas.

Configurations

MODEL	LENGTH	LUMENS	COLOUR TEMP	INPUT	MOUNTING
SLT	4 (4ft)	L	4K (4000K)	M (120-347V)	[Blank] Surface Mount with V-Hook

DLC PRODUCT ID: SLT-4L-4K-M (Premium: S-EVP6DH/Standard: S-OH5CFM)

Pre-Built Inventory

ORDERING CODE	SHORT DESCRIPTION	LONG DESCRIPTION
19001807	SLT-4L-4K-M	4FT LED STRIP WITH SENSOR 4585LM 35W 120-347V 4000K SURFACE MOUNT WITH V-HOOK

Accessories

ORDER CODE	DESCRIPTION
50001060	Continuous row mounting aligner for suspended installation
50001075	Replacement lens 48"
50001018	Wireguard kit 48"

HOUSING:

24 gauge white powder painted steel housing. Sleek, compact design for installation in tight spaces.

ELECTRICAL:

Available in 4000K. High efficiency driver operates 120V through 347V.

L70 at 155,000 hours.

OCCUPANCY SENSOR:

Integrated tri-level microwave (high-frequency) motion sensor.

OPERATING TEMPERATURE:

-20°C to 55°C

MOUNTING:

- Surface mount, suspended, or row mounted (see accessories).
- V-Hooks, canopy plate for octagonal junction box, and mounting brackets are included.

DIMMING:

Default programming has standby dimming at 20%.

WEIGHT:

6.3 lbs. / 2.9 kg.

WARRANTY:

5 year LED warranty, see website for full warranty details.

SLT LED Strip With Sensor



Dimensions

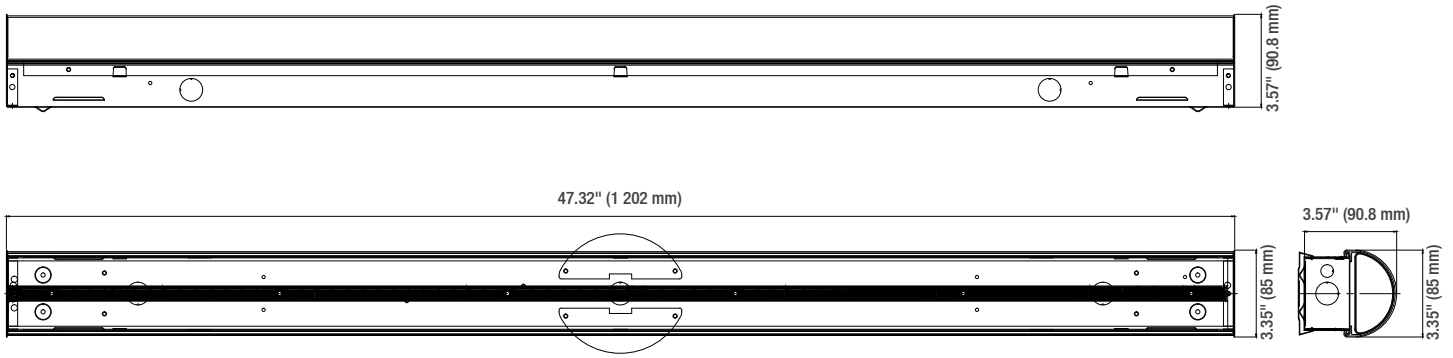

SLT-4L-4K-M

Luminous Intensity Distribution

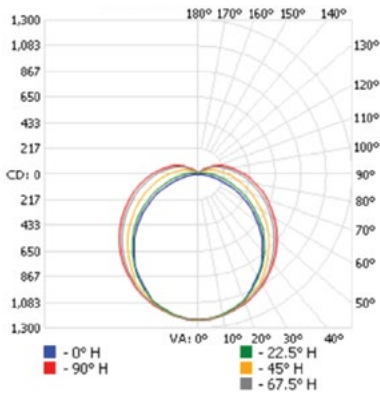

Zonal Lumen Summary

ZONE	LUMENS	% LUMINAIRE
0-30	954	20%
0-40	1569	33%
0-60	2846	61%
60-90	1266	27%
70-100	939	20%
90-120	442	9%
0-90	4112	88%
90-180	543	11%
0-180	4655	100%

Energy Chart

MODEL	LENGTH	EFFICACY	WATTAGE	LUMEN OUTPUT ¹	CRI	L70 HOURS ²
SLT-4L-4K-M	4ft	131 lm/W	35	4 585	80+	155,000

¹Lumen values are derived from photometric testing. Initial lumens range: +/- 10 %.

²Life hours are derived from IESNA LM-80-08 testing report and projected per IESNA TM-21-11 extrapolations