



FORTEZZA™ EXIT COMBO

Wet Location IP66 & Vandal Resistant Exit Combo



Project Name: _____ Model Number: _____
 Prepared By: _____ Date: _____

FEATURES & BENEFITS

- Heavy gauge die-cast aluminum housing
- UV resistant polycarbonate faceplate
- Vandal resistant to withstand extreme abuse
- MR16 halogen or LED lamps, up to 50W
- AC only and UDC Signs: -20 to +40°C
- Self-powered Sign: +10 to +40°C
- Low temperature -40°C / Internal heater -20°C
- Salt Spray Passed
- 120/277/347VAC input
- CSA 22.2 No. 141-15 Performance Certified

DIMENSIONS

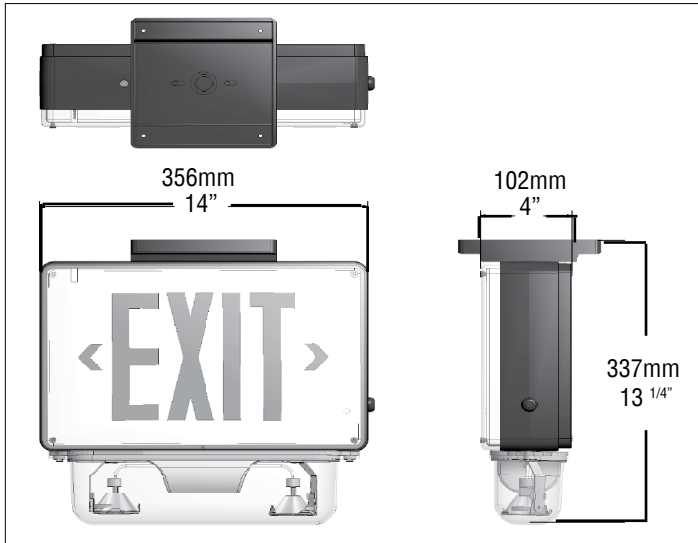

LAMP SELECTION	6V	12V
MR16	N/A	50W
LED	5W	2, 5, 7W

ORDERING GUIDE

FTZ-C - - - - -

SERIES	WATTS	LED	FACE#	MOUNTING	LAMP	OPTIONS
FTZ-C	See Model Rating Guide	LR (Red)	1 (Single)	¹ U (Universal Std) ² W (Wall) C (Ceiling) ¹ E (End)	See Lamp Selection	AT (Auto-test) BB (Black face, black body) WW (White face, white body) PK (Pendant kit) ¹ IH (Internal heater -20°C) ¹ LT (Low temperature -40°C)

NOTE: ¹6V36W or 12V72W w/120VAC only; ²Single face only.

EXTERNAL SPECIFICATIONS

The FORTEZZA™ is constructed from .420" thick, heavy duty cast aluminum. The face plate is protected by high abuse clear polycarbonate, which is recessed into the housing. Tamper resistant screws are standard and ensure the integrity of the unit. The FORTEZZA™ comes standard in black although colour options are available upon request. The FORTEZZA™ comes standard with an external LED status indicator and test switch. The lamp housing is constructed from a vandal-resistant polycarbonate for maximum durability.

INTERNAL SPECIFICATIONS

Standard versions use nickel-cadmium or nickel-metal hydride batteries to provide a minimum of 30 minutes of emergency duration. Two stage charger and transfer are standard.

BELUCE AUTO-TEST (AT)

The system automatically performs one 5 minute discharge test monthly and every 6 months it performs two 30 minute discharge tests, 24 hours apart. This tests both full battery capacity and recharge capability.

BATTERY TECHNOLOGY

Designed with a maintenance free, sealed nickel-cadmium battery providing a minimum emergency duration of 30 minutes. Optional 120 minute nickel-cadmium batteries are available. Recharge time of the battery is 24 hours.

MODEL RATING GUIDE

MODEL	VOLTAGE (OUT-PUT)	WATTAGE RATING
FTZ-C-6-36	6	36
FTZ-C-6-50	6	50
FTZ-C-12-20	12	20
FTZ-C-12-40	12	40
FTZ-C-12-72	12	72
FTZ-C-12-100	12	100